

DUAL CLUTCH

DISMANTLING AND REASSEMBLY

DISMANTLING

1. Carefully punch mark the clutch cover, the outer pressure plate and the two inner pressure plates, so that they can be assembled in the same relative position, to maintain the balance of the clutch assembly.
2. Place the assembly in a press with the cover assembly uppermost, place a bar or piece of wood across the centre of the cover and apply pressure downward, until the clutch release levers are just free.

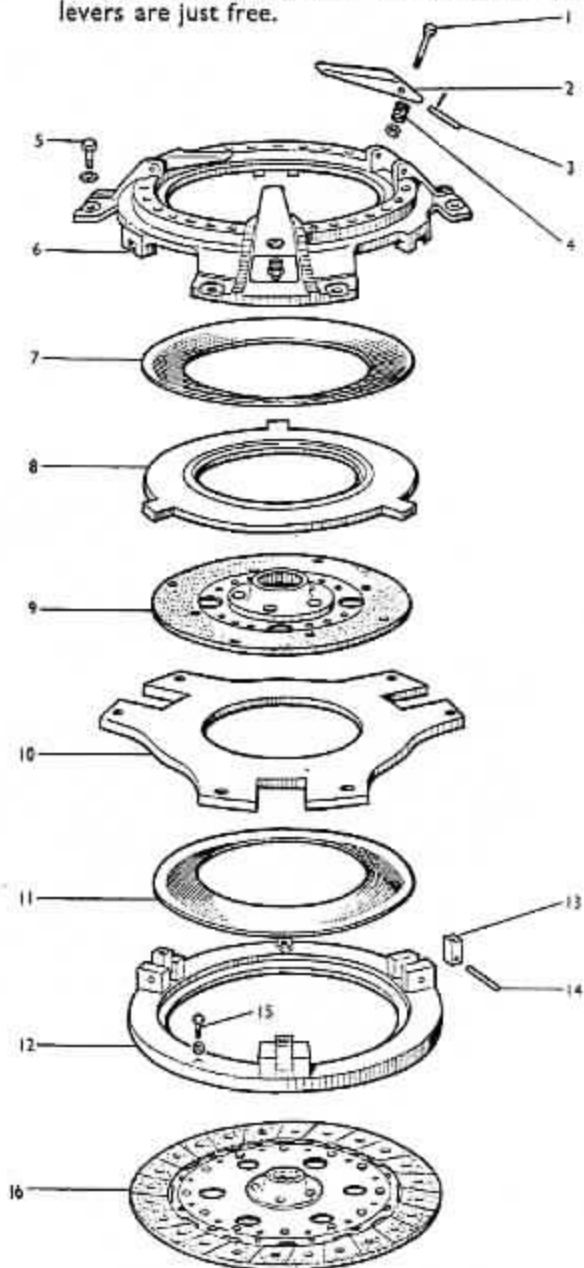

FIG. 14 EXPLODED VIEW OF DUAL CLUTCH

3. Loosen the locknuts on the adjusting screws and turn the screws completely out of the clutch rod ends. Release the pressure on the clutch and it can now be dismantled.

Note that the clutch release lever pins are secured by a small roll pin driven through the lever pin and into a hole in the clutch cover. If the release levers have been damaged, and require replacing, the lever pins can be removed by driving them out of the assembly with a small punch in the direction of the roll pin, this will pull the roll pin from the hole in the front cover. Use new roll pins when replacing the release lever pins.

REASSEMBLY

NOTE. The Belleville Springs and clutch disc hub splines should be lubricated with a light smear of "Lubriplate" 70 grease (Export Market only) or "Keenol" K.G.20 and K.G.15 grease. The latter is manufactured by Messrs. Duckham & Co. Ltd., Hammersmith, London, W.6.

If these products are not available, use a molybdenum disulphide grease which has been entirely satisfactory for the Clutch Splines of the TE-20 type Tractors.

1. Place the inner pressure plate (12) face down on the work bench. Place primary Belleville spring (marked with a red stripe) (11) on the pressure plate with the convex side up. *It is most important for the edge of the spring to be accurately seated in its locating groove and not to be dislodged during subsequent assembly.*
 2. Place the second pressure plate (10), with the flat side up, in position on the assembly by lining up the punch marks previously made.
 3. Place and centre the secondary disc assembly (9) on the pressure plate with the longer hub of the disc up. Place the outer pressure plate (8) on the assembly with the flat side against the disc. Again line up the punch marks.
 4. Place the second clutch spring (marked with a yellow stripe) (7) on the assembly with the concave side up. Place the clutch cover (6) in position, again lining up the punch marks and carefully locating the secondary Belleville spring in its groove.
- N.B.—The primary and secondary Belleville springs are identical dimensionally and in spring rates. However, the primary spring, (marked with a red stripe on the concave side for identification purposes) is of special material and must always be fitted in the front position.
5. Place the assembly in a press and again place a bar or piece of wood across the centre of the cover assembly. Apply just sufficient pressure with the press to get the adjusting screws started into the clutch end rods. Tighten the adjusting screws part way down and remove the assembly from the press.